

SUMMARY:

The Kelowna Memorial Park Cemetery Bylaw outlines the regulations for the maintenance and operation of the cemetery. Included in the bylaw are license requirements; fees charged for interment, disinterment, use and care of grave sites; and the restrictions regarding interment including grave size and depth, hours and size and types of monuments permitted.

This bylaw is a 'consolidated' version and includes amendments up to the date listed in the bylaw heading. It is placed on the Internet for convenience only, is not the official or legal version, and should not be used in place of certified copies which can be obtained through the Office of the City Clerk at City Hall. Plans, pictures, other graphics or text in the legal version may be missing or altered in this electronic version.

CITY OF KELOWNA

BYLAW NO. 8807

Revised: June 21, 2010

CONSOLIDATED FOR CONVENIENCE TO INCLUDE: BYLAW NO. 9289,
9487, 9738, 9783 and 10358

KELOWNA MEMORIAL PARK CEMETERY BYLAW

A bylaw to provide for the regulation, maintenance and operation of
the Kelowna Memorial Park Cemetery

BL9289 amended the words "Licence", "Cemetery Licence" or "Cemetery Licences" be replaced with the words "Right of Interment" or "Rights of Interment" and all references "*Cemetery and Funeral Service Act*" be replaced with "*Cremation, Interment And Funeral Services Act*" and that all references to the "*Local Government Act*" be deleted and replaced with "*Community Charter*"; wherever they appear in the bylaw as follows:

BL 9487 deleted the words "Family Estates" and replaced with the words "Garden Estates" wherever they appear in the bylaw as follows:

The Council of the City of Kelowna pursuant to Section 8 of the *Community Charter*, in open meeting assembled, enacts as follows:

PART 1 - GENERAL

1.1 Title

1.1.1 This bylaw shall be known for all purposes as the "Kelowna Memorial Park Cemetery Bylaw No. 8807".

1.2 Interpretation

1.2.1 Enactments. Any enactment referred to herein is a reference to an enactment of British Columbia or Canada, as the case may be, and regulations thereto, as amended, revised, consolidated or replaced from time to time, and any bylaw referred to herein is a reference to an enactment of the Council of the City of Kelowna, as amended, revised, consolidated or replaced from time to time.

1.2.2 Headings. The headings given to the Parts, Sections and Paragraphs in this Bylaw are for convenience of reference only. They do not form part of this Bylaw and will not be used in the interpretation of this Bylaw.

1.2.3 Severability. If any Part, Section or phrase of this Bylaw is for any reason held to be invalid by the decision of a Court of competent jurisdiction, such decision will not affect the validity of the remaining portions of this Bylaw.

BL9289 and BL9783 amended Schedules:

1.2.4 Schedules. The following schedules attached to this Bylaw form part of this Bylaw:

- Schedule A - Schedule of Fees
- Schedule B - Right of Interment
- Schedule C - Interment Permit
- Schedule D - Surrender of Transfer of Right of Interment
- Schedule E - Installation Permit
- Schedule F - Monument Specifications
- Schedule G - Map

1.3 Definitions

1.3.1 In this bylaw, unless the context otherwise requires:

BL9738 amended "Bennett Memorial Columbarium":

"Bennett Memorial Columbarium" means the columbarium in Section D around Bennett Memorial Circle Drive consisting of 12 Concord structures of 32 (32) niches each, one (1) round dome structure consisting of 72 niches and two (2) curved wall structures consisting of 60 niches each.

"Caretaker" means the person duly appointed or employed as such by the City.

"Cemetery" means the Kelowna Memorial Park Cemetery and includes any other parcel or tract of land owned, used or maintained by the City as a cemetery.

"Cemetery Manager" means the person duly appointed or employed as such by the City.

"City" means the City of Kelowna.

"Clerk" means the person duly appointed as Officer Assigned Responsibility for Corporate Administration of the City by the Council and includes his delegate.

"Council" means the Municipal Council of the City of Kelowna.

"Director" means the person duly appointed from time to time by the Council to act as Director of Parks & Leisure Services for the City and includes his delegate.

BL9289 added the definition "Family Estates" and BL9487 renamed it "Garden Estates":

"Garden Estates" means a fenced or semi fenced space intended to be used for the interment of human remains and/or cremated human remains under a Right of Interment. A Garden Estate consists of two (2) double depth in-ground lawn crypts and eight (8) companion in-ground cremation plots.

"Immediate Family" means a parent or stepparent, a grandparent or step-grandparent, a sibling (natural, adopted or step), a spouse, a common-law spouse, a same-sex spouse, a child (natural, adopted or step) or a grandchild (natural, adopted or step).

"Medical Health Officer" means the person duly appointed from time to time by the Council to act as Medical Health Officer for the City.

"Niche" means each individual compartment to be used for the interment of cremated remains in a columbarium or mausoleum.

"Pioneer Section" means the non-grassed areas of Section A and Section B.

"Plot" means a space used or intended to be used for the interment of human remains or cremated remains under a right of interment and includes a grave, crypt, niche or plot;

"Promontory Green Interment Garden" means the mausoleum in Section G of the Cemetery consisting of mausoleum crypts, niches, in-ground interment for cremated remains and a scattering garden.

BL9289 added the definition "Right of Interment":

"Right of Interment" means a right, in perpetuity, for the interment of human remains or cremated remains, in a lot.

"Scattering Garden" means a designated area for the placement of non-recoverable, commingled cremated remains placed within an ossuary or scattered within the designated garden area.

"Section A" of the Cemetery means the non-grassed area consisting of Rows A to L (inclusive), Rows 1 to 47, and the grassed area with upright monuments being Row G Lot 16 to Row L Lot 15 inclusive as shown on Schedule "G".

"Section B" of the Cemetery means the non-grassed area consisting of Rows 60 to 77 (inclusive) as shown on Schedule "G".

"Section C" of the Cemetery means the grassed area consisting of Rows 78 to 103 (inclusive) as shown on Schedule "G".

"Section D" of the Cemetery means the grassed area consisting of Rows 104 to 224 (inclusive) as shown on Schedule "G".

"Section E1" of the Cemetery means the grassed area consisting of Rows M to U as shown on Schedule "G".

"Section E2" of the Cemetery means the grassed area consisting of Rows 220 to 253 (821 plots) as shown on Schedule "G".

"Section E3" of the Cemetery means the grassed area consisting of Rows 254 to 285 (635 plots) as shown on Schedule "G".

"Section E4" of the Cemetery means the non-grassed area consisting of Rows 287 to 306 (584 plots) as shown on Schedule "G".

"Section E5" of the Cemetery means the non-grassed area consisting of 2,000 cremation plots as shown on Schedule "G".

"Section G1" of the Cemetery means the grassed area consisting of double depth in-ground lawn crypts as shown on Schedule "G".

BL9289 amended definition of "Section G2":

"Section G2" of the Cemetery means the above ground wall comprising of the mausoleum, niche and memorial wall in the Promontory Green Interment Garden as shown on Schedule "G". The purchase of a mausoleum crypt, niche or memorial wall in Section G2 includes a standard name plate and opening and closing.

BL9289 amended definition of "Section G3":

"Section G3" of the Cemetery means the grassed area within the Promontory Green Interment Garden consisting of companion (3" x 3") and family cremation plots (3" x 6") as shown on Schedule "G".

"Section G4" of the Cemetery means the grassed area consisting of full size burial plots as shown on Schedule "G".

BL9289 amended definition of "Section G5":

"Section G5" of the Cemetery means the grassed area consisting of companion (3" x 3") and family cremation (3" x 6") plots as shown on Schedule "G".

BL9289 amended definition of "Section G6":

"Section G6" of the Cemetery means the grassed area consisting of companion (3" x 3") and family cremation (3" x 6") plots as shown on Schedule "G".

BL9289 added the definition "Section G7"; BL9487 and BL9738 replaced it:

"Section G7" of the Cemetery means the grassed area consisting of double-depth in-ground lawn crypts memorialized by either a flat ground or upright marker according to design of the row and Garden Estates as shown on Schedule "G"

"Treasurer" means the person duly appointed as the Officer Assigned Responsibility for Financial Administration of the City by the Council and includes his delegate.

PART 2 - CITY OF KELOWNA CEMETERY BOUNDARIES

2.1 The following lands as shown on Schedule "G", are hereby set aside, and are held, operated, used or maintained as a Cemetery by the City:

- (a) Part of Lot 2 District Lot 140 ODYD Plan KAP69306;
- (b) Part of Amended Lot 3 (DD252160F) District Lot 140 Plan 1476;
- (c) Part of Lot B District Lot 140 ODYD Plan KAP62742;
- (d) That Part of Lot 18 shown on Plan B3723 Sections 28 and 29 Township 26 and of District Lot 531 ODYD Plan 1476;
- (e) Part of Parcel B (DD244966F) of the Southeast ¼ of Section 29 Township 26 ODYD;
- (f) Part of Lot 1 Sections 28 and 29 Township 26 and of District Lots 531 and 125 ODYD Plan 16707 except Plan M14878.

BL9289 amended sub-section 2.2:

2.2 Cemetery Plans. A copy of the plans of the Cemetery shall be kept available for public inspection at the Cemetery and such places that may be deemed necessary.

PART 3 - RIGHT OF INTERMENT

3.1 Reserved Sections. The City may by agreement with a society, church, or other organization, reserve a section of the Cemetery to be used exclusively for the interment of deceased members of the society, church, or other organization. Upon such an agreement being made no person shall be issued a **Right of Interment** for the reserved section, unless the application for a **Right of Interment** is accompanied by a certificate from the society, church, or organization, stating that the individual is entitled to interment in the reserved section. All **Rights of Interment** issued and services rendered by the City, under these conditions, shall be subject to payment at the regular rates set forth in Schedule "A".

BL9289 amended sub-section 3.2:

- 3.2 **Right of Interment for Exclusive Use.** The Cemetery Manager is hereby authorized by Council to grant to any person, or to his authorized agent, paying the fees set forth in Schedule "A" and subject to the terms of this Bylaw, a **Right of Interment** for the exclusive use by him, or his executors or administrators, of any one or more plots which may be vacant and not issued as a **Right of Interment** in the Cemetery and upon payment of said fee, such person or his authorized agent shall be entitled to receive a **Right of Interment** in the general form of Schedule "B".
- 3.3 **Right of Refusal.** The Council reserves the right to refuse to sell a **Right of Interment** for the use of more than two plots to any one individual.
- 3.4 **Right of Interment Not Transferable** The holder of a **Right of Interment** shall not transfer his right of use and occupancy to another person except that at the discretion of the Cemetery Manager, a transfer of the **Right of Interment** for any unused plot may be made to an immediate family member provided the fee for the transfer has been paid as outlined in Schedule "A". In an area of the Cemetery that has been reserved by the City under section 3.1 of this bylaw for burial of members of the society, church, or other organization the application for transfer must be accompanied by a certificate stating that the individual is entitled to interment in the reserved section.

BL9287 replaced sub-paragraph 3.5:

- 3.5 **Transfer Request** The transfer request must be in writing by the holder of a **Right of Interment** as set out in Schedule "D". **Right of Interments** for plots must be surrendered, and a transfer fee as set out in Schedule "A" shall be paid to the City. The Cemetery Manager shall amend his records accordingly stating the new holder of the **Right of Interment** of the plot or plots.
- 3.6 **Notice of Transfer.** To ensure the accuracy of records of ownership and interments, no sale or other transfer of any plot, or any interest therein shall be binding upon the City until a duly executed transfer has been submitted to the Cemetery Manager specifying the name, address or other description of the proposed transferee, and such particulars shall be recorded in a register to be kept for that purpose.
- 3.7 **Proof of Inheritance.** When the owner of a plot dies and the ownership passes to the new owners before the new owners can obtain registration of their interest to it, the City may require proof of their right to such interest. This proof in ordinary cases may consist of a will or other such proof as may be satisfactory to the City;

If the new owner wishes to have an interment made before he/she has obtained registration of his/her interest in a plot, he/she shall satisfy the City of his/her right to do so before the interment shall be permitted.

- 3.8 **Order of Priority.** The right of a person to control the disposition of the human remains or cremated remains vests in and devolves on that person in the order of priority as outlined in the *Cremation, Interment And Funeral Services Act*:

BL9289 amended sub-paragraph 3.9:

- 3.9 **Right of Interment Cancellation.** Upon receiving a written request by the holder of a **Right of Interment** to forfeit such right to use and occupy grave space, the Cemetery Manager may cancel the **Right of Interment** and refund the holder of a **Right of Interment** a sum equivalent to that paid for such **Right of Interment** less the Maintenance fee paid at the time of **Right of Interment** issuance.

If goods have been specially pre-ordered and because of some unique characteristic, personalization or extraordinary cost, the goods cannot be used in the ordinary course of business, the cemetery may deduct the itemized cost of those goods from the holder of a **Right of Interment** and the cost of those goods may be retained out of any money paid for the purposes of a **Right of Interment** cancellation. Should the plot that is to be surrendered have any memorial, surround or coping, the Cemetery may deduct the cost to remove and dispose of such memorials out of any monies paid for the purposes of a **Right of Interment** cancellation.

- 3.10 **Right of Interment Provisions.** All **Right of Interment** shall be subject to the provisions of this bylaw and to all bylaws now or hereafter adopted by Council.

PART 4 - FEES AND CHARGES

- 4.1 **Fees for Interments.** The fees for interment, disinterment, use of **plots**, and care of graves, and the charges for goods offered for sale by the **City** for use in the **Cemetery**, and any other **Cemetery** fees shall be those set out in Schedule "A".
- 4.2 **Payment of Fees.** The fees set out in Schedule "A" shall be paid at the **City** offices at the time of purchasing a **Right of Interment**, Interment Permit, or any goods or services sold by the **City** in connection with the operation of the **Cemetery**.

BL9289 and BL9783 amended sub-paragraph 4.3:

- 4.3 **Installment Plan.** Plots may be purchased on the installment plan and in advance of need with a twenty percent (20%) deposit. When such purchases are made, full and final payment of the monies owed must be made within one (1) year of purchase or prior to any interment, placement of memorial stone or transfers into the **plot**.

If balance is not paid after one (1) year, the **City** reserves the right to refund all monies paid on account less the maintenance fund contribution plus an administration fee and re-issue the **plot**.

If goods have been specially pre-ordered and because of some unique characteristic, personalization or extraordinary cost, the goods cannot be used in the ordinary course of business, the cemetery may deduct the itemized cost of those goods from the **Right of Interment** and the cost of those goods may be retained out of any money paid for the purposes of a **Right of Interment** cancellation.

BL9487 amended the title for PART 5 - PERMISSION TO INTER, EXHUME AND CREMATE:

PART 5 - PERMISSION TO INTER, EXHUME OR DISINTER

BL9487 amended sub-section 5.1:

- 5.1 **Interment Permit.** No human remains or cremated remains shall be interred in the Cemetery until;
- (a) a person having authority pursuant to Section 5 of the Cremation, Interment and Funeral Services Act of B.C. to authorize the disposition of the deceased person's human remains or cremated remains has completed, duly signed and witnessed at the Cemetery Office an interment authorization and / or any other documents required to facilitate the interment in a form approved by the City of Kelowna.

- (b) a permit to inter the remains has been obtained from the City and the fee for interment as specified in Schedule "A" has been paid, except as may be permitted otherwise under the terms of Sections 5.5, 5.6 and 5.7 of this bylaw.

5.2 Permit Form. All permits for interment of deceased persons in the Cemetery shall be in the form of Schedule "C".

BL9289 replaced sub-section 5.3:

5.3 Application for Permit All applications for an interment permit must be made at least 24 hours (1 working day), and during the winter months from November 1 to March 15 of each year 48 hours (2 working days); the Pioneer Section requires 48 hours (2 working days) before the scheduled interment, to the Cemetery Manager between the hours of 8:00 a.m. and 4:00 p.m. on all days of the week except Saturday and Sunday, Statutory Holiday, and in cases of emergency, as described in Sections 5.5, 5.6 and 5.7 of this bylaw.

5.4 Registration of Death. All persons applying for interments in the Cemetery shall furnish to the Cemetery Manager, the Registration of Death or Cremation Certificate and the following information for the purpose of record as required, before such interment be allowed:

- (a) The full name of the deceased and name of the property owner if not the same.
- (b) Place of birth.
- (c) Place of death.
- (d) Cause of death.
- (e) Age.
- (f) Day, date and time of interment.
- (g) Type of grave liner.
- (h) Plot, lot, and or grave number in cases of pre-purchased family plots into which the deceased is to be interred.
- (i) Name of Funeral Home.
- (j) The name(s) and related addresses of the person(s) to receive the Licence for the plot.
- (k) The name(s) and related addresses of the next of kin.

BL9289 amended sub-paragraph 5.5:

5.5 Interment After Hours. Where a Medical Health Officer directs that a body be buried in the Cemetery during any period when the Cemetery is closed, permission to inter in the Cemetery shall be obtained from the Cemetery Manager, or in his absence, the Clerk.

BL9783 amended sub-paragraph 5.6:

5.6 Details of Deceased. Where an interment in the Cemetery is performed under the conditions of Section 5.5 of this Bylaw, the person who permitted the interment and the person who performed the interment shall report the matter to the Cemetery Manager and the representative of the deceased shall furnish the Cemetery Manager with full details of the deceased as required by Section 5.4 of this Bylaw.

5.7 Provide Information. The information required to be given to the Cemetery Manager under the terms of Section 5.6 of this Bylaw shall be provided to the Cemetery Manager as soon after such interment as the City's offices are opened.

- 5.8 Order to Exhume. No deceased person interred in the Cemetery shall be exhumed except in compliance with the requirements of the *Cremation, Interment and Funeral Services Act* and upon payment of any fee required by and in compliance with all terms and conditions of this bylaw. The City's responsibility will end at the point where the soil is sufficiently excavated to permit access to the remains for removal by the attending funeral provider. The City is not responsible for damage to any casket, urn or other container sustained during exhumation.
- 5.9 Lawful Interment. It shall be unlawful to inter or cremate a deceased person within the Municipal boundary of the City except pursuant to the terms of the *Cremation, Interment and Funeral Services Act* and Regulations thereunder.
- 5.10 Disinterment No interment in the Cemetery shall be disinterred except in compliance with the *Cremation, Interment and Funeral Services Act* and upon payment of any fee required by and in compliance with all terms and conditions of this bylaw. The City's responsibility will end at the point where the soil is sufficiently excavated to permit access to the remains for removal by the attending funeral provider.

PART 6 - INTERMENT IN THE CEMETERY

- 6.1 Human Remains Only. Only human remains and cremated remains shall be interred in the Cemetery and all interments shall be subject to and comply with the provisions of this bylaw.
- 6.2 Occupy Plot. The holder of a **Right of Interment** to use and occupy a plot in the Cemetery may transfer his right of use and occupancy to another family member subject to Section 3 of this Bylaw.
- 6.3 Communicable Disease. Where the remains of a person who died while suffering a communicable disease are to be buried in the Cemetery, any instruction given by the **Medical Health Officer** respecting the interment shall be fully and carefully followed by those who perform the interment.
- 6.4 Inform Caretaker. Where the body delivered to the Cemetery for interment is subject to direction of the **Medical Health Officer**, pursuant to the *Health Act*, the person delivering the body to the Cemetery shall so inform the **Caretaker**.
- 6.5 Grave Depth. Each interment in the Cemetery, other than the interment of cremated remains or in a lawn crypt, shall be made in a grave, which when filled and closed, provides not less than 0.914 m (3 ft.) of earth between the general surface level of the ground at the grave site and the upper surface of the vault, casket or grave liner enclosing the body resting in the grave.

BL9289 and BL9487 replaced sub-paragraph 6.6:

- 6.6 Number of Interments In Sections C, D, E1, E2, E3 and G4 and in the upright monument portion of Sections A, B and E4 where the grave top is not covered by hard surfacing, two (2) casket interments plus two (2) cremations will be permitted in each large plot. In Section G1 and G7 Lawn Crypts, only two (2) interments are allowed. An additional use fee will be applied for the third and subsequent burial in a single plot. The Garden Estates in Section G7 are exempt from the additional use fee.

- 6.7 Lower Depth. Where two interments are permitted in one plot and each interment is in respect to a body not in the form of cremated remains, the first interment shall be at a lower depth than the second and each of the two interments in the one grave shall comply with the requirements of Section 6.5 of this Bylaw.
- 6.8 Depth of Cremated Remains. Each interment of cremated remains in the Cemetery shall be made in a container encased in concrete or reinforced fibreglass or other material as approved by the City and shall be buried in the plot not less than 0.610 m (2 ft.) deep.
- 6.9 Grave Liners. A concrete or reinforced fibreglass grave liner shall be used for each interment, except where a concrete or steel vault is used or cremated remains are interred according to the requirements of Section 6.8 of this Bylaw.
- 6.10 Scattering of Cremated Remains. It shall be unlawful for any person to scatter cremated remains within the confines of the Cemetery except within a scattering garden. The scatter of cremated remains within the Promontory Green garden will consist only of a small portion of remains, where the majority of cremated remains are placed in an ossuary. All cremated remains that are placed in the scattering garden or ossuary are considered non-recoverable and commingled. The placement of cremated remains in the ossuary will only be performed by Cemetery Staff.
- 6.11 Liner Material. Each grave liner used in the Cemetery shall be made of concrete or reinforced fibreglass or other material, as approved by the Cemetery Manager.
- 6.12 Upright Monuments - Grave Space Embellishments (Cemetery Section E4). In Section E4 except for graves or grave spaces embellished prior to the date of this bylaw, no grave space shall be defined by a curb, coping, fence, railing or other means save by an upright marker and as specified in Schedule "F".
- 6.13 Hours of Interment. Except as otherwise authorized in this bylaw, no person shall inter any remains in the Cemetery except between the hours of 8:00 a.m. and 4:00 p.m.

BL9289 amended sub-section 6.14:

- 6.14 No Interment on Weekends or Statutory Holidays. No person shall inter any body in the Cemetery on Saturday or Sunday or any Statutory Holiday unless written permission of the Cemetery Manager is first obtained except in the emergency conditions as specified in Sections 5.5, 5.6 and 5.7 of this bylaw.

BL9289 and BL9738 amended sub-section 6.15:

- 6.15 Grave Digging, Opening or Closing. No grave shall be dug, opened or closed by any person other than the Caretaker and his assigned helpers or other person duly authorized by the City. Witnesses to a grave closing must adhere to WorkSafe B.C. rules and regulations with the respect of safety and only with permission by the Cemetery Manager.
- 6.16 No Above Ground Structures. No structure for interment above ground shall be erected in Sections C, D, E1, E2 and E3 of the Cemetery, and each interment in the Cemetery shall conform to the requirements of Sections 6.5 to 6.11 of this Bylaw inclusive except where a vault or mausoleum already in the Cemetery contains space which a deceased person is entitled to occupy in which case interment may be permitted therein.

- 6.17 **Bennett Memorial Columbarium.** Notwithstanding the provisions of sub-sections 6.5 to 6.11 inclusive of this part, cremated remains may be placed in a container and secured in a niche of the **Bennett Memorial Columbarium**. The administration and operation of the columbarium shall be carried out in accordance with this bylaw.
- 6.18 **Promontory Green Interment Garden.** Notwithstanding the provisions of this section, the human remains or cremated remains may be interred in the **Promontory Green Interment Garden**. The administration and operation of the **Promontory Green Interment Garden** shall be carried out in accordance with this bylaw.
- 6.19 **Containers.** Human remains must be interred in a container that does not exceed 64 cm high x 76 cm wide x 221 cm long, provided the container that does not exceed the size of the **plot**, so long as the holder of the Interment Permit provides, at his or her sole cost, a grave liner large enough to contain the container. All containers of human remains must be placed within a grave liner or precast concrete crypt.
- 6.20 **Cremated Remains Container.** For every interment of cremated remains in a container, the grave will be dug to a depth sufficient to ensure that there are not less than 30 centimetres of earth between the top of the container and the level of the ground surrounding the grave. For every interment of cremated remains in a vault-type Memorial Marker, the grave will be dug to a depth sufficient to ensure that the Memorial Marker, once installed, is level with the surface of the ground. For every interment of cremated remains in a **niche**, the container(s) for cremated remains shall be made of metal, stone, or porcelain and must be manufactured for the express purpose of containing cremated remains. A single container or combination of (2) two containers shall not exceed 27 cm high x 27 cm wide x 27 cm deep and for the **Bennett Memorial Columbarium**, the container(s) for cremated remains shall not exceed 27 cm high x 27 cm wide x 36 cm deep.

PART 7 - DIRECTOR OF PARKS & LEISURE SERVICES

- 7.1 Notwithstanding any other provision contained herein, the **Director** shall be responsible for ensuring that the provisions of this bylaw are properly carried out.
- 7.2 The **Director** shall engage such staff as may be necessary to carry out the administrative and operational duties necessary under this bylaw, subject to **Council's** approval.
- 7.3 Any contracted personnel or **City** staff engaged in performing any duty under the jurisdiction of this bylaw shall be under the supervision of the **Director**.

PART 8 - CEMETERY CARETAKER

- 8.1 **Duties of Caretaker.** Pursuant to Section 7.2 of this Bylaw, **Council** may authorize the appointment of a **Caretaker** and the duties and responsibilities of a **Caretaker** so appointed shall be, among other things, to carry out, or cause to be carried out by workmen placed under his supervision:
- (a) the digging, preparation, opening and closing of graves as ordered by the **Cemetery Manager**, or by the **Clerk**, pursuant to this bylaw;
 - (b) the direction of all funerals in the **Cemetery** to the correct **plot**;
 - (c) the general work of the **Cemetery** grounds to maintain same in a neat and tidy condition; and

(d) the provision of care for the City-owned tools and equipment.

8.2 Caretaker Maintains Records. The **Caretaker** shall maintain records as directed by the **Cemetery Manager** and shall submit reports as required by him, and shall do such other work as the **Cemetery Manager** may require from time to time in relation to the Cemetery operation.

PART 9 - ADMINISTRATION AND MAINTENANCE

9.1 Administrative Records. The **Cemetery Manager** shall maintain such records as are necessary for the administration and management of the **Cemetery** and as are required by the *Cremation, Interment and Funeral Services Act*.

9.2 Subdivision Not Permitted Effective the date of adoption of this bylaw, no subdivision of plots will be permitted.

BL9289 replaced sub-section 9.3:

9.3 Grant Right of Interment. The **Cemetery Manager** is hereby authorized on behalf of the **City** to grant a **Right of Interment** in the form set out in Schedule "B" in respect of any vacant and not issued **Right of Interment plot** in the **Cemetery**, according to the fees and charges specified in Schedule "A" and subject to the provisions of this bylaw.

9.4 Issues Permits. The **Cemetery Manager** shall issue all interment permits required by this bylaw, except as otherwise provided herein.

9.5 Notify Caretaker. Upon issuing any interment permits, or upon receiving an order for disinterment from the proper authority, the **Cemetery Manager** shall notify the **Caretaker** before the time of the intended interment or disinterment giving the name of the deceased and the number and location of the **plot** concerned.

9.6 Maintenance Fund A fund shall be established to be known as the "Cemetery Maintenance Fund" and administered in accordance with the *Cremation, Interment And Funeral Services Act* and the *Community Charter*. The interest in this fund shall be used for the upkeep, care and repair of the **Cemetery**. The principal in this fund shall not be reduced other than in accordance with an order made pursuant to the *Cremation, Interment And Funeral Services Act*.

9.7 Replacement Fund A fund shall be established to be known as the "Cemetery Replacement Fund". This fund shall be administered as a reserve fund in accordance with the *Community Charter*. The principal and interest in this fund shall be used for the purchase and development of land for cemetery purposes in the future.

9.8 Reserve Accounts. Accounts shall be established to be known as the "Cemetery Maintenance Fund Account" and the "Cemetery Replacement Fund Account" respectively, into which the **Treasurer** shall pay the separate amounts received for each aforesaid respective Fund purpose, and such funds shall be held in the respective account pending investment as hereinafter provided.

9.9 Payments to Reserve Accounts. On all **Right of Interment Fees** for use of **Cemetery Plots**, and **Reservation Fees for Cemetery Plots**, the **Treasurer** shall pay into the "Cemetery Maintenance Fund Account" and the "Cemetery Replacement Fund Account" respectively, from the amount received for each **Right of Interment** or reservation sold, the fees as specified in Schedule "A".

- 9.10 Reserving Plots. On all **Right of Interment** for the use of or reservation of cemetery plots, and on all contracts or agreements for the sale of such **Right of Interment**, the amount required to be used for "Cemetery Maintenance Fund" and "Cemetery Replacement Fund" purposes shall be specified.
- 9.11 Markers. Any owner of a memorial marker, tablet, or monument, or memorial and curbing desiring to install, or modify, same in the Cemetery shall pay to the City prior to the installation or modification of same, the fee specified in Schedule "A", as a contribution to the "Cemetery Maintenance Fund", and such amounts when received shall be paid by the Treasurer into the "Cemetery Maintenance Fund Account" for investment as hereinafter provided.
- 9.12 Monies Held in Trust. All monies received and deposited by the Treasurer in the "Cemetery Maintenance Fund" and "Cemetery Replacement Fund" accounts shall be held and invested as trust funds to be devoted solely to the purposes for which they were received.
- 9.13 The Cemetery Fund. A separate account of all monies received under the provisions of this bylaw and all monies expended hereunder shall be kept by the Treasurer and any surplus remaining of receipts over expenditures shall be paid at the end of each fiscal year into a fund to be known as "The Cemetery Fund" and same shall be invested by the City in accordance with the provisions of the *Local Government Act* and the principle and interest derived from such investment shall be expended on the upkeep and development of the Cemetery.

PART 10 - ADORNMENT

- 10.1 Floral Offerings. For the purpose of regular maintenance, only fresh cut flowers, wreaths and floral offerings may be placed on graves in sections which are grassed covered during the period March 16th to October 31st in any year, and during this period no person shall place or cause to be placed on the graves in sections which are grassed covered any artificial flowers or plants, vases or decorative containers or ornaments or any other offerings except as outlined herein.
- 10.2 Artificial Flowers. Artificial flowers may be placed on graves in sections which are grassed covered during the period November 1st to the following March 15th in any year, and if not removed by March 15th will be removed by the Caretaker, stored for one month and destroyed or disposed of at that time if not claimed.
- BL9289 amended sub-paragraph 10.3:
- 10.3 Removal of Offerings. The Caretaker may remove and dispose of any offerings as from any grave when the condition is considered by him to be a safety hazard, detrimental to the beauty, or impedes maintenance, of the Cemetery. The Cemetery cannot be held accountable for any offerings removed by an act of vandalism.
- 10.4 Planting Restrictions. No person shall plant, remove, cut down or destroy any trees, shrubs, plants, flowers or bulbs in the Cemetery other than a person authorized by the City to do so.

10.5 No Adornment Except as specifically provided in the bylaw, no part of the Cemetery or plot may be adorned in any manner by any person other than a Caretaker without the express authority of the Cemetery Manager, with the exercise of such authority to be within the Cemetery Manager' sole discretion and, for greater clarity but without limiting the general prohibitive language of this section, nor part of the Cemetery or plot may be adorned by any one or more of the following:

- (a) arbours, trellis, fences, curbs, rails or other structures;
- (b) trees, shrubs, hedges or plants, other than potted flowering plants of not more than 50 centimetres in height and width, which plants the City reserves the express right to remove and destroy or otherwise destroy of at any time after the placement of the same in order to facilitate maintenance of the Cemetery or due to the condition of the plant, and in any event, no later than seven days after placement.
- (c) Objects of remembrance or any other objects of any type whatsoever.

MEMORIALS

10.6 Permit Required Every person who desires to have installed or modified a memorial marker or tablet, on any plot or grave within the Cemetery, shall make application to the Cemetery Manager at the offices of the City for a permit in the form set out in Schedule "E", and shall, with such application, pay the fees set out in Schedule "A".

BL9289 replaced sub-section 10.7:

10.7 Enclosures No grave or grave space shall be bounded or enclosed by a fence, hedges, railing except those that are allowed in the Pioneer Section or the Garden Estates of the Cemetery that are part of the design feature.

BL9289 amended sub-section 10.8:

10.8 Specifications Only memorials of the tablet variety and manufactured from stone, bronze, or any other material approved by the Cemetery Manager, which conform to the specifications as set out in Schedule "F", shall be placed and installed in the Cemetery, as follows:

- (a) Each memorial marker shall be placed horizontally flat and level with the surrounding ground.
- (b) Only one (1) memorial tablet shall be placed and installed on a Child, Infant/Stillborn or Cremation plot regardless of interment depth.

BL9783 amended sub-paragraph 10.8(c):

(c) Where cremation memorial tablets are placed on a full-size adult plot in accordance with Schedule "F", the first cremation tablet shall be centred and set directly below the full size memorial. Each of the following cremation memorials shall, in turn, be centred directly below each other.

- (d) Where an upright memorial is placed in a Family Estate only one (1) will be permitted and shall not exceed the width and depth of the foundation provided. Where cremation memorial tablets are placed between the full-size adult plots in accordance with Schedule "F", the first cremation tablet shall be centred and set directly upon the cremation plot. Each of the following cremation memorials shall, in turn, be centred directly below each successive cremation plot. All ornamentation such as benches, large vases and other adornments must be made of granite or other materials that meet the approval of the Cemetery Manager.

- 10.9 Replacements Requests to have a new memorial tablet placed, to replace an existing memorial or to modify a memorial shall be made in the form set out in Schedule "E" together with payment of re-setting fee as set out in Schedule "A". All such requests must be with the consent of the next-of-kin; or may be granted at the discretion of the Cemetery Manager should the next-of-kin not be known, or unable to be located.
- 10.10 Temporary Markers During the period from November 1st to the following March 15th in any year, temporary grave markers as approved by the Cemetery Manager may be used in all sections of the Cemetery. Temporary markers may not be used at other times and will be removed by the Caretaker.
- 10.11 Only Authorized Personnel No memorial shall be placed, installed, or removed within the Cemetery by any persons other than the Caretaker or other person duly authorized to do so by the Cemetery Manager.
- 10.12 Not Liable The City shall not be held liable for any breakage or damage to any memorial tablet or monument in the Cemetery, except as shall arise as the result of negligence or carelessness of the Caretaker or other employee of the City.
- 10.13 Tablets All memorial markers delivered to the Cemetery must meet the specifications set out in Schedule "F". All memorial markers delivered to the Cemetery require a signature by the Cemetery Staff upon delivery. Any memorial marker that has been delivered to the Cemetery that does not meet the specifications set out in Schedule "F", or for which an Installation Permit has not been issued, will be kept for 30 days and then returned to the Company from which it was delivered at the Companies expense for the return of such memorial marker.
- 10.14 Removal Should any memorial, marker, or tablet, grave cover or grave curbing placed or erected in the Cemetery be in a state of disrepair such that it might be hazardous to the public or detrimental to the maintenance of the Cemetery, the Cemetery Manager may, after 30 days notice in writing to the next-of-kin at his last known address, have the memorial, marker, or tablet, grave cover or grave curbing removed from the Cemetery if it has not been repaired in accordance with the notice.

PIONEER SECTION

- 10.15 Permit Required No person shall erect any monument or place any memorial or construct any curbing or ledger around any plot, or portion of a plot, in the Pioneer Section until they have paid the fees as set out in Schedule "A" and have receive a permit in accordance with Schedule "E". Only plots, which have received the second (2nd) full size interment, will be considered to allow a concrete ledger.
- 10.16 Costs of Removal Should any excessive sized monument, curbing, ledger placed in the Pioneer Section be require to be removed to accommodate an interment, the cost of such work is the responsibility of the family or their agent. The City will endeavour to do such removals with care and caution, but will not be responsible for the repair or cost of repair for damage to an excessive sized monument, curbing or ledger that is placed in the Pioneer Section prior to the interment.

- 10.17 Information Required Prior to obtaining such permit the applicant shall file with the **Cemetery Manager** a statement setting forth in detail:
- (a) The size of the base of the proposed monument;
 - (b) The weight of the said monument;
 - (c) The material of which said monument is constructed;
 - (d) The size of the proposed memorial marker and the material of which it is to be constructed; and
 - (e) The number of lineal feet of curbing required.
 - (f) A sketch of the project, including, but not limited to size, thickness of ledger, size and intervals of re-enforcement bar and other materials used.
- 10.18 Placement All memorials erected in the **Pioneer Section** shall be placed to the specifications of the **Cemetery Manager**, and must be constructed of granite or bronze and have a base of at least 150 mm (6 inches) which may be constructed of concrete.
- 10.19 Prohibited Materials No monument or curbing shall be constructed of wood, and the use of marble for monuments or memorial markers is expressly prohibited.
- 10.20 Curbing All curbing shall be of cement or granite and must be laid by the applicant or their agent so as to form a proper joint with the adjoining curb.
- All cement curbs shall have a facing of 150 mm (6 inches) and a depth of 250 mm (10 inches) and shall be set 150 mm (6 inches) above grade at **plot line**, and shall be set on a solid foundation.
- Reinforcement bar must be placed within the curb at intervals and size of diameter of reinforcement bar based on standard construction processes.
- 10.21 Ledger Concrete ledger must be a minimum of 4 inches thick with reinforcement mesh placed within the ledger based on standard construction practices.
- 10.22 Notification The **Cemetery Manager** shall be notified no less than one week before any monument is erected, or curbing or a cement ledger is laid on any grave.

PART 11 - GENERAL REGULATIONS

- 11.1 Cemetery Damage. No person shall damage or deface any memorial, monument, fence, gate, or structure in the **Cemetery**, or any improvements in the **Cemetery**.
- 11.2 Damage to Cemetery. Any person who wilfully destroys, mutilates, defaces, injures, or removes any tomb, monument, memorial, or other structure placed in the **Cemetery**, or any fence, railing or other work for the protection or ornament of the **Cemetery**, or any tomb, monument, memorial, or other structure aforesaid or **plot** within the **Cemetery**, or wilfully destroys, cuts, breaks or injures any shrub or plant, or plays at any game or sport, or who wilfully or unlawfully disturbs persons assembled for the purpose of interring a body therein, or who commits a nuisance, or at any time behaves in an indecent and unseemly manner, or deposits any rubbish or offensive matter or thing in the **Cemetery**, or in any way violates any grave, tomb, tomb-stone, vault, memorial or other structure within the same shall be guilty of an infraction of this bylaw and be liable on summary conviction therefor to the penalties hereinafter set out.

11.3 Cemetery Access/Speed. No person shall enter the Cemetery in a vehicle after sunset, or drive a vehicle in the Cemetery at any time at a speed of more than 10 miles per hour (15 km/h), and all vehicles and their drivers while in the Cemetery grounds shall be subject to the directions and orders of the Caretaker.

BL9738 amended Section 11.4:

11.4 Solicitation. No person shall solicit orders for markers, tablets, memorials, curbing, cappings, or like works within the limits of the Cemetery other than those authorized by the Cemetery Manager.

11.5 Obey Caretaker. All persons and funeral processions in the Cemetery shall obey the reasonable instructions of the Caretaker, and any person not behaving with proper decorum within the Cemetery, or disturbing the quiet and good order of the Cemetery may be evicted therefrom by the Caretaker.

11.6 Discharging Firearms. The discharge of firearms, other than as authorized by the Cemetery Manager, is prohibited in the Cemetery.

11.7 Hours of Operation. The Cemetery shall be open between the hours of 7:00 a.m. and 8:00 p.m. during the period March 16th to October 31st each year and between the hours of 7:00 a.m. and 5:00 p.m. during the period of November 1st to March 15th each year. Any person in the Cemetery after these hours without special permission of the Caretaker, Cemetery Manager, or other person authorized by the City to grant such permission, shall be deemed guilty of an infraction of this bylaw and liable on summary conviction therefor to the penalties thereof.

11.8 Penalties. Any person guilty of an infraction or violation of any of the provisions of this bylaw shall be liable, on summary conviction, to a fine of up to Two Thousand Dollars (\$2,000.00).

11.9 Temporary Removal of Markers. The Cemetery Manager may arrange for the temporary removal of a marker without the owner's permission if, during the excavation of an adjoining grave, the marker is found to be a hazard to the safety of workers in the excavation or to gain access to a plot for grave site preparation, provided that the marker is replaced in its original position on the grave from which it was removed as soon as possible after the excavation has been filled, and provided that the owner of the marker is not charged with the cost of the work, unless he is also the owner of the plot in which the excavation is being made, and provided also that the City or its agents repairs at its expense any damage occasioned to the marker so removed and replaced.

11.10 General Maintenance. General maintenance work which will be performed without cost to the plot or grave owner includes the cutting and/or removal of grass and weeds, gathering of leaves and trash, maintaining roads in passable condition, watering of serviced areas, shade tree care and such grading and improvements to grounds as may be necessary at the discretion of the Cemetery Manager.

BL9289 amended sub-paragraph 11.11:

11.11 Excessive Maintenance. Areas which create excessive maintenance, such as plots or groups of plots, enclosed or surrounded by concrete, ornamental rock cover, walls, hedges, shrubs, trees, monuments, raised memorials or other edifices are the responsibility of the families to be kept clean and tidy. The City and its employees will not be liable or responsible for loss or damage, or any repairs necessitated by or caused from an Act of God, the elements, thieves, vandals, unavoidable accidents, insurrection or other cause.

11.12 Right to Correct Errors. The City reserves, and shall have the right to correct any errors that may be made by it, either in making interments, disinterments or removals, or in the inscriptions, transfer, or conveyance by substituting and conveying in lieu thereof other interment rights of equal value and similar location as far as possible, or as may be selected by the City or, in the sole discretion of the City, by refunding the amount of money paid on account of said purchase. In the event such error shall involve the interment of the remains of any person in such property, the City reserves and shall have the right to remove and transfer such remains so interred, to such other property of equal value and similar location as may be substituted and conveyed in lieu of. The City shall not be liable in respect to any such errors, except as aforesaid.

PART 12 - REPEAL AND ENACTMENT

12.1 Effect of Bylaw. This bylaw shall come into full force and effect and be binding on all persons as and from date of adoption.

12.2 Repeal. "Kelowna Memorial Park Cemetery Bylaw No. 7627" and all amendments are hereby repealed.

Read a first, second and third time by the Municipal Council this 24th day of June, 2002

Received approval in principle under the *Cremation, Interment and Funeral Services Act* this 17th day of June, 2002

Adopted by the Municipal Council of the City of Kelowna this 15th day of July, 2002

"Walter Gray"

Mayor

"Allison Flack"

Deputy City Clerk

Filed with the Office of the Business Practices and Consumer Protection Authority this

Director

BL9738 and BL9783 amended Schedule "A" as follows:

KELOWNA MEMORIAL PARK CEMETERY FEE SCHEDULE

PRODUCT/SERVICE	April 1, 2007	January 1, 2008
 Burial Services		
INTERMENT - CASKET	634.00	650.00
INTERMENT - CREMATED REMAINS	276.00	283.00
DISINTERMENT - CASKET	1,104.00	1,131.00
DISINTERMENT - CREMATED REMAINS	276.00	283.00
INTERMENT - CHILDREN UNDER 12 YEARS OF AGE		
CONCRETE LINER OR REINFORCED FIBREGLASS LINER - LARGE	441.00	452.00
CONCRETE LINER OR REINFORCED FIBREGLASS LINER - CREMATION	138.00	141.00
CONCRETE CONTAINER OR REINFORCED FIBREGLASS LINER CHILDS	166.00	170.00
HANDLING & PLACING VAULTS SUPPLIED BY FUNERAL HOME	276.00	283.00
Price list for INSTALLATION OF PLAQUES BY CITY IN SECTIONS C, D, E1,E2,E3,G3,G4,G5 & G6		
CEMETERY MAINTENANCE FUND	114.00	117.00
INSTALLATION	171.00	175.00
Total	285.00	292.00
 INSTALLATION OF MEMORIAL (ALL TYPES) BY OTHERS IN PIONEER SECTION AND UPRIGHT SECTIONS OF SECTION G - MARKER UPRIGHT PERMIT		
	166.00	170.00
MODIFICATION (RE-SETTING) OF MEMORIAL	56.00	57.00
WEEKEND/HOLIDAY FEE	431.00	441.00
INTERMENTS AFTER 3:00 PM	265.00	271.00
CANOPY SERVICE (2ND TENT)	93.00	96.00
IN-GROUND GALVANIZED FLOWER VASE HANDLING & PLACING VASE SUPPLIED BY FUNERAL HOME	58.00	59.00
ADMINISTRATION FEE	22.00	23.00
ADDITIONAL USE FEE (3RD/+ BURIAL)	56.00	57.00
DEEPENING LARGE LOT	276.00	283.00
DEEPENING CREMATION LOT	1104.00	1131.00
SUPPLY 2ND YEAR PLATE	276.00	283.00
DISPOSAL OF MARKER TO SUPPLY PALL BEARER PER (2 EMPLOYEES)	83.00	85.00
ENGRAVING OF GRANITE SHUTTER	75.00	77.00
	81.00	83.00
	210.00	215.00

KELOWNA MEMORIAL PARK CEMETERY FEE SCHEDULE

PRODUCT/SERVICE	April 1, 2007	January 1, 2008
RIGHT OF INTERMENT - PROMONTORY GREEN INTERMENT GARDEN CREMATION PLOT - SECTION G3 - COMPANION PLOT 3'x3'		
PLOT PRICE	358.00	367.00
CEMETERY REPLACEMENT FUND	180.00	184.00
CEMETERY MAINTENANCE FUND	180.00	184.00
Total	718.00	735.00
RIGHT OF INTERMENT - CREMATION PLOT - SECTION G5 & G6 - FAMILY PLOT 3'x6'		
PLOT PRICE	551.00	565.00
CEMETERY REPLACEMENT FUND	276.00	283.00
CEMETERY MAINTENANCE FUND *	276.00	283.00
Total	1,103.00	1,131.00
RIGHT OF INTERMENT - CREMATION PLOT - G5 & G6 - COMPANION PLOT 3'x3'		
PLOT PRICE	276.00	283.00
CEMETERY REPLACEMENT FUND	138.00	141.00
CEMETERY MAINTENANCE FUND	138.00	141.00
Total	552.00	565.00
RIGHT OF INTERMENT - CREMATION PLOTS - SECTION C (1.5' x 2') & SECTION D (2.5' x 1.5')		
PLOT PRICE	166.00	170.00
CEMETERY REPLACEMENT FUND	83.00	85.00
CEMETERY MAINTENANCE FUND	83.00	85.00
Total	332.00	340.00
MEMORIAL WALL SPACE		
PLOT PRICE	221.00	226.00
CEMETERY REPLACEMENT FUND	110.00	113.00
CEMETERY MAINTENANCE FUND	110.00	113.00
Total	441.00	452.00
RIGHT OF INTERMENT - PROMONTORY GREEN INTERMENT GARDEN SCATTERING GARDEN OSSUARY INCLUDES NAME PLATE		
PLOT PRICE	221.00	226.00
CEMETERY REPLACEMENT FUND	110.00	113.00
CEMETERY MAINTENANCE FUND	110.00	113.00
Total	441.00	452.00

KELOWNA MEMORIAL PARK CEMETERY FEE SCHEDULE

PRODUCT/SERVICE	April 1, 2007	January 1, 2008
RIGHT OF INTERMENT - PROMONTORY GREEN INTERMENT GARDEN NICHE, SECTION G2 - LEVEL 1, INCLUDES STANDARD NICHE PLATE AND OPENING & CLOSING		
PLOT PRICE	1,379.00	1,413.00
CEMETERY REPLACEMENT FUND	1,104.00	1,131.00
CEMETERY MAINTENANCE FUND	276.00	283.00
Total	2,759.00	2,827.00
RIGHT OF INTERMENT - PROMONTORY GREEN INTERMENT GARDEN NICHE, SECTION G2 - LEVEL 2, INCLUDES STANDARD NICHE PLATE AND OPENING & CLOSING		
PLOT PRICE	1,462.00	1,498.00
CEMETERY REPLACEMENT FUND	1,170.00	1,199.00
CEMETERY MAINTENANCE FUND	292.00	299.00
Total	2,924.00	2,996.00
RIGHT OF INTERMENT - PROMONTORY GREEN INTERMENT GARDEN NICHE, SECTION G2 - LEVEL 3, INCLUDES STANDARD NICHE PLATE AND OPENING & CLOSING		
PLOT PRICE	1,517.00	1,555.00
CEMETERY REPLACEMENT FUND	1,214.00	1,244.00
CEMETERY MAINTENANCE FUND	273.00	280.00
Total	3,004.00	3,079.00
RIGHT OF INTERMENT - PROMONTORY GREEN INTERMENT GARDEN NICHE, SECTION G2 - LEVEL 4, INCLUDES STANDARD NICHE PLATE AND OPENING & CLOSING		
PLOT PRICE	1,462.00	1,498.00
CEMETERY REPLACEMENT FUND	1,170.00	1,199.00
CEMETERY MAINTENANCE FUND	292.00	299.00
Total	2,924.00	2,996.00
RIGHT OF INTERMENT - PROMONTORY GREEN INTERMENT GARDEN CREMATION PLOT, SECTION G3 - FAMILY PLOT 3'x6'		
PLOT PRICE	662.00	678.00
CEMETERY REPLACEMENT FUND	331.00	339.00
CEMETERY MAINTENANCE FUND	331.00	339.00
Total	1,324.00	1,356.00

KELOWNA MEMORIAL PARK CEMETERY FEE SCHEDULE

PRODUCT/SERVICE	April 1, 2007	January 1, 2008
RIGHT OF INTERMENT - BENNETT MEMORIAL COLUMBARIUM - CURVED WALL LEVEL 2, ENGRAVING EXTRA, INCLUDES OPENING & CLOSING		
PLOT PRICE	1,462.00	1,498.00
CEMETERY REPLACEMENT FUND	1,170.00	1,199.00
CEMETERY MAINTENANCE FUND	292.00	299.00
Total	2,924.00	2,996.00
RIGHT OF INTERMENT - BENNETT MEMORIAL COLUMBARIUM - CURVED WALL LEVEL 3, ENGRAVING EXTRA, INCLUDES OPENING & CLOSING		
PLOT PRICE	1,517.00	1,555.00
CEMETERY REPLACEMENT FUND	1,214.00	1,244.00
CEMETERY MAINTENANCE FUND	273.00	280.00
Total	3,004.00	3,079.00
RIGHT OF INTERMENT - BENNETT MEMORIAL COLUMBARIUM - ROUND UNIT - LEVEL 1 & 6, ENGRAVING EXTRA, INCLUDES OPENING & CLOSING		
PLOT PRICE	1,379.00	1,413.00
CEMETERY REPLACEMENT FUND	1,104.00	1,131.00
CEMETERY MAINTENANCE FUND	276.00	283.00
Total	2,759.00	2,827.00
RIGHT OF INTERMENT - BENNETT MEMORIAL COLUMBARIUM - ROUND UNIT - LEVEL 2 & 5, ENGRAVING EXTRA, INCLUDES OPENING & CLOSING		
PLOT PRICE	1,462.00	1,498.00
CEMETERY REPLACEMENT FUND	1,170.00	1,199.00
CEMETERY MAINTENANCE FUND	292.00	299.00
Total	2,924.00	2,996.00
RIGHT OF INTERMENT - BENNETT MEMORIAL COLUMBARIUM - ROUND UNIT - LEVEL 3 & 4, ENGRAVING EXTRA, INCLUDES OPENING & CLOSING		
PLOT PRICE	1,517.00	1,555.00
CEMETERY REPLACEMENT FUND	1,214.00	1,244.00
CEMETERY MAINTENANCE FUND	273.00	280.00
Total	3004.00	3,079.00

KELOWNA MEMORIAL PARK CEMETERY FEE SCHEDULE

PRODUCT/SERVICE	April 1, 2007	January 1, 2008
Total	276.00	283.00
RIGHT OF INTERMENT - SECTION G7 - SEMI-PRIVATE ESTATE; INCLUDES 2 DOUBLE-DEPTH LAWN CRYPTS, 8 COMPANION CREMATION PLOTS, MARKER FOUNDATION, SHARED GRANITE BENCH AND GARDEN BEDS		
PLOT PRICE	19,663.00	20,155.00
CEMETERY REPLACEMENT FUND	9,831.00	10,077.00
CEMETERY MAINTENANCE FUND	9,831.00	10,077.00
Total	39,325.00	40,309.00
RIGHT OF INTERMENT - SECTION G7 - PRIVATE ESTATE; INCLUDES 2 DOUBLE-DEPTH LAWN CRYPTS, 8 COMPANION CREMATION PLOTS, MARKER FOUNDATION, GRANITE BENCH, ARCHED GATE FEATURE C/W BRONZE NAME PLATE AND GARDEN BEDS		
PLOT PRICE	26,658.00	27,325.00
CEMETERY REPLACEMENT FUND	13,330.00	13,663.00
CEMETERY MAINTENANCE FUND	13,330.00	13,663.00
Total	53,318.00	54,651.00
RIGHT OF INTERMENT - BENNETT MEMORIAL COLUMBARIUM - CONCORD - INCLUDES BRONZE WREATH - OPEN / CLOSING EXTRA		
PLOT PRICE	1,246.00	1,278.00
CEMETERY REPLACEMENT FUND	624.00	639.00
CEMETERY MAINTENANCE FUND	188.00	193.00
Total	2,058.00	2,110.00
RIGHT OF INTERMENT - BENNETT MEMORIAL COLUMBARIUM - CURVED WALL LEVEL 1, ENGRAVING EXTRA, INCLUDES OPENING & CLOSING		
PLOT PRICE	1,379.00	1,413.00
CEMETERY REPLACEMENT FUND	1,104.00	1,131.00
CEMETERY MAINTENANCE FUND	276.00	283.00
Total	2,759.00	2,827.00

KELOWNA MEMORIAL PARK CEMETERY FEE SCHEDULE

PRODUCT/SERVICE	April 1, 2007	January 1, 2008
RIGHT OF INTERMENT - G2 MAUSOLEUM COUCH CRYPT, LEVEL 1,2,&3, INCLUDES STANDARD CRYPT PLATE, VASE AND OPENING & CLOSING		
PLOT PRICE	9,372.00	9,607.00
CEMETERY REPLACEMENT FUND	7,498.00	7,686.00
CEMETERY MAINTENANCE FUND	1,874.00	1,921.00
Total	18,744.00	19,214.00
RIGHT OF INTERMENT - G2 SINGLE CRYPT LEVEL 1, INCLUDES STANDARD CRYPT PLATE, VASE AND OPENING & CLOSING		
PLOT PRICE	5,626.00	5,767.00
CEMETERY REPLACEMENT FUND	4,501.00	4,614.00
CEMETERY MAINTENANCE FUND	1,126.00	1,154.00
Total	11,253.00	11,535.00
RIGHT OF INTERMENT - G2 SINGLE CRYPT LEVEL 2, INCLUDES STANDARD CRYPT PLATE, VASE AND OPENING & CLOSING		
PLOT PRICE	6,752.00	6,920.00
CEMETERY REPLACEMENT FUND	5,401.00	5,536.00
CEMETERY MAINTENANCE FUND	1,350.00	1,384.00
Total	13,503.00	13,840.00
RIGHT OF INTERMENT - G2 SINGLE CRYPT LEVEL 3, INCLUDES STANDARD CRYPT PLATE, VASE AND OPENING & CLOSING		
PLOT PRICE	6,360.00	6,519.00
CEMETERY REPLACEMENT FUND	5,087.00	5,214.00
CEMETERY MAINTENANCE FUND	1,272.00	1,303.00
Total	12,719.00	13,036.00
RIGHT OF INTERMENT - SECTION A,D SMALL PLOT (3'x5')		
PLOT PRICE	138.00	141.00
CEMETERY REPLACEMENT FUND	69.00	71.00
CEMETERY MAINTENANCE FUND	69.00	71.00

KELOWNA MEMORIAL PARK CEMETERY FEE SCHEDULE

PRODUCT/SERVICE	April 1, 2007	January 1, 2008
RIGHT OF INTERMENT - G7 LAWN CRYPT (Upright Marker) NO LINER REQUIRED		
PLOT PRICE	1,936.00	1,984.00
CEMETERY REPLACEMENT FUND	663.00	680.00
CEMETERY MAINTENANCE FUND	861.00	883.00
Total	3,460.00	3,547.00
RIGHT OF INTERMENT - G1, G7 LAWN CRYPT (Flat Marker G 7) NO LINER REQUIRED		
PLOT PRICE	1,379.00	1,413.00
CEMETERY REPLACEMENT FUND	690.00	707.00
CEMETERY MAINTENANCE FUND	690.00	707.00
Total	2,759.00	2,827.00
RIGHT OF INTERMENT - G4 LARGE PLOT (Upright Marker)		
PLOT PRICE	927.00	950.00
CEMETERY REPLACEMENT FUND	463.00	475.00
CEMETERY MAINTENANCE FUND	463.00	475.00
Total	1,853.00	1,900.00
RIGHT OF INTERMENT - G4 LARGE PLOT (Flat Marker)		
PLOT PRICE	662.00	678.00
CEMETERY REPLACEMENT FUND	331.00	339.00
CEMETERY MAINTENANCE FUND	331.00	339.00
Total	1,324.00	1,356.00
RIGHT OF INTERMENT - SEC C,D,E (5'x10")		
PLOT PRICE	463.00	475.00
CEMETERY REPLACEMENT FUND	232.00	238.00
CEMETERY MAINTENANCE FUND	232.00	238.00
Total	927.00	951.00
RIGHT OF INTERMENT - SEC A,B (5'x10')		
PLOT PRICE	232.00	238.00
CEMETERY REPLACEMENT FUND	116.00	118.00
CEMETERY MAINTENANCE FUND	116.00	118.00
Total	464.00	474.00

BL9289 and BL10358 replaced amended Schedule "B":

SCHEDULE "B"

KELOWNA MEMORIAL PARK CEMETERY

1991 BERNARD AVENUE, KELOWNA BC V1Y 9V7 RIGHT OF INTERMENT NO.

RIGHT OF INTERMENT RECEIPT NO.

INCONSIDERATION

(Name or Company)

AS AGENT FOR

(Right of Interment)

OF

(Right of Interment address)

HAVING PAID THE SUM SHOWN IN THE RECEIPT BELOW FOR A RIGHT OF INTERMENT,
PERMISSION IS HEREBY GRANTED TO:

(Name of person
to be interred)

TO USE OR OCCUPY:

This Right of Interment is subject to Kelowna Memorial Park Cemetery Bylaw No. 8807 as amended or replaced from time to time, and any other bylaw applicable thereto being in force in the City of Kelowna. In granting the Right of Interment, the City of Kelowna undertakes to maintain a Cemetery Maintenance Fund for the maintenance of the grave space specified herein and the Cemetery of which it forms part, and will set aside within the present calendar year for the use of the Cemetery Maintenance Fund a portion of the fee as specified below.

The Right of Interment is hereby notified in accordance with the *Cremation, Interment and Funeral Services Act* that prior to the installation of any marker, monument or curbing on the grave site sold, the purchaser must pay to the City of Kelowna the fee in effect as specified by the Cemetery Bylaw in force at the time of payment, as a contribution to the Cemetery Maintenance Fund.

NOTE: This Right of Interment is not transferable. DATED _____

ISSUED BY: _____

ACCOUNT NO.	DESCRIPTION OF FEES	AMOUNT
	RIGHT OF INTERMENT FEE	
	CEMETERY MAINTENANCE FUND	
	CEMETERY REPLACEMENT FUND	
	APPLICABLE TAXES	
		TOTAL DUE

\$20.00 Service charge for returned cheques.
A returned cheque invalidates this receipt.
This receipt is not valid unless stamped and signed.

TERMS AND CONDITIONS OF RIGHT OF INTERMENT (Schedule "B")

A refund for cancellation of Right of Interment will be a sum equivalent to that paid for such Right of Interment at the time of issuance less the maintenance fee paid at the time of issuance.

1. This Right of Interment is for the use of the plot only and all fees and charges relate solely to the plot and do not include any other charges, including without limitation, charges for:
 - (a) grave services, such as opening and closing graves at time of interment or disinterment
 - (b) provision of grave liners
 - (c) provision of cremated remain liners
 - (d) permits for the installation of Memorial Markers
 - (e) additional use fee for the 3rd or subsequent burial

all of which charges will be assessed at the time of actual interment in accordance with the fees and charges then in effect under the bylaw or any subsequent bylaw.

2. The Right of Interment is conditional upon the Applicant complying in all respects with the terms and conditions of this bylaw and the *Cremation, Interment and Funeral Services Act*. A failure by the Applicant to so comply will entitle the City to either correct the failure at the Applicant's cost or, where interment in the plot has not yet occurred, revoke this Right of Interment upon repayment to the Applicant of the plot price less the Cemetery Maintenance Fund.
3. Subject to the City's rights to reclaim the plot pursuant to the *Cremation, Interment and Funeral Services Act*, the plot may be surrendered to the City at any time, the City will pay to the legal owner of such plot the plot price paid pursuant to this agreement less the Cemetery Maintenance Fund.
4. The City reserves the right to procure, store, or install goods covered by this agreement, and to be reimbursed immediately for any goods or services that have been prepaid in advance of need. In return, the City guarantees to deliver the goods and services when required without additional charge. Any funds paid by the City for goods and services under this agreement will not be refundable to the Purchaser once the City has started to discharge the obligation to provide these goods and services even if only by the pre-need procurement, storage or installation of these goods. Should the plot that is to be surrendered have any memorial, surround or coping, the Cemetery may deduct the cost to remove and dispose of such memorials out of any monies paid for the purposes of a Right of Interment cancellation.

The foregoing terms and conditions of the Right of Interment are hereby acknowledged and agreed to by the Applicant.

DATED AT KELOWNA, BC this _____ day of _____ 20 .

Signature of Applicant

BL9289 and BL10358 amended Schedule "C":

SCHEDULE "C"

KELOWNA MEMORIAL PARK CEMETERY

1991 BERNARD AVENUE, KELOWNA, BC V1Y 9V7

INTERMENT PERMIT RECEIPT NO.

IN CONSIDERATION OF THE SUM AS DETAILED IN THE RECEIPT BELOW BEING PAID AND UPON PRESENTATION OF "NOTICE OF REGISTRATION OF DEATH" OR A "WARRANT TO BURY" ISSUED BY A CORONER; PERMISSION IS HEREBY GIVEN

TO _____ (Name or Company)

TO HAVE THE REMAINS/ASHES OF _____ (Name of person to be interred)

INTERRED IN SECTION ROW LOT

AT A DEPTH OF: ON:

DATED _____

ISSUED BY: _____

ACCOUNT NO.	DESCRIPTION OF FEES	AMOUNT
	SUPPLY AND PLACE LINER	
	OPENING AND CLOSING GRAVE	
	WEEKEND AND HOLIDAY FEE	
	WEEKDAY FUNERAL AFTER 3:00 P.M.	
	APPLICABLE TAXES	
	OTHER (SPECIFY)	

	TOTAL DUE	\$

\$20.00 Service charge for returned cheques.
A returned cheque invalidates this receipt.
This receipt is not valid unless signed and imprinted by cash register.

BL10358 amended Schedule "D":

**SCHEDULE "D"
SURRENDER OR TRANSFER OF LICENSE**



1991 Bernard Avenue, Kelowna B.C. V1Y 9V7
Telephone (250) 862-5518
Fax (250) 862-5520

SURRENDER or TRANSFER OF RESERVED PLOT

Row: _____ Plot: _____

I hereby surrender to the City of Kelowna the above reserved plot, as registered under Right of Interment No. _____. OR

I hereby transfer to _____(Transferee) the above reserved plot, as registered under Licence No. _____.

Signed: _____

Name: _____

Address: _____

Telephone: _____

Dated: _____

TRANSFEEE INFORMATION

Name: _____

Address: _____

Telephone: _____

Refund on Surrendered Plot	
Original price paid for Plot	
\$ _____*	
less the Maintenance Fund contribution and cost of procured goods)	
Plus applicable taxes on *	\$ _____

REFUND TOTAL	
\$ _____	
Cheque Number _____	
Date _____	
Signature _____	
Transfer Fee \$50.00	

Schedule E



1991 Bernard Avenue, Kelowna B.C. V1Y 9V7
Telephone (250) 862-5518
Fax (250) 862-5520

PERMIT FOR INSTALLATION OF MEMORIAL TABLET

_____ of _____
(Agent) (Address)

_____ shall pay the sum of \$ _____ (plus taxes)

being the amount of the fees due therefor, is hereby granted a permit for the

installation removal/reinstallation Pioneer Section

of a _____ memorial tablet, in consideration of
(Marker size)

_____ in
(Owner)

(section) _____ (block) _____ (lot) _____ (row) _____ in the Kelowna Memorial Park Cemetery, and in accordance with and subject to all by-laws, rules and regulations for the regulation of Kelowna Memorial Park Cemetery and any by-law or law in force in the City of Kelowna and applicable thereto which may for the time being be in force.

Dated this _____ day of _____, 20_____.

Cemetery Operations Clerk
Kelowna Memorial Park Cemetery

Note: NO memorial shall be placed, installed or removed within the Cemetery by any Persons other than the Caretaker of the Cemetery or other person duly authorized to do so by the Director.

BL9289 and BL9487 amended Schedule "F":

Schedule "F"

MEMORIALS

1. Letters, numerals or ornamentation on a memorial tablet shall not protrude beyond one-half inch (1/2"), above the finished concrete surface surrounding the tablet.

BL9738 deleted Section 2:

2. No memorial marker that is placed horizontally flat after June 1, 2002 shall have a photographic appliqué that is attached by adhesive of any type. Crosses or other emblems of any kind are not allowed unless they are an integral part of the memorial and made of granite, bronze or other permanent materials, which have been approved by the Cemetery Manager.
3. All Grave markers or monuments are the property of the Purchaser and required care or repair is the responsibility of the owner (Purchaser).
4. No personal tribute may be placed on or adjacent to a Columbarium. The cost of the memorialization is included in the fees for the niche required by this bylaw. Any other memorialization must be approved by the Cemetery Manager and must meet the City's requirements to keep the continuity of design of the Columbarium
5. All marker sizes are measured in inches and are always written **length x width x height**. All memorial markers are required to have a border or margin of two inches (2"), clear of any lettering or ornamentation; this may be achieved in the following manner:

Stone (granite preferred)

The tablet shall be installed in a concrete base not less than four inches (4"), thick and shall include a two inch (2"), border or margin surrounding the tablet, and shall have its side surfaces true and perpendicular with its top surface. All side surfaces shall be roughened appropriately to ensure proper bonding when installed in the concrete base.

Bronze

Each bronze memorial tablet shall be set in a concrete base not less than four inches (4"), thick and shall include a two inch (2"), border or margin surrounding the bronze memorial tablet.

OR

Each bronze tablet shall be set on a stone (granite preferred) minimum three inches (3"), thick with a two (2"), border or margin free of any lettering or ornamentation.

6. The top surface measurements for memorial tablets shall be as follows:

(i) On Full Size Adult Plots

(A) Minimum 20" x 12" followed by up to two (2) cremation memorials to commemorate additional cremation interments.

(B) *Maximum 28" x 16"; or where two (2) full size adult plots have been purchased side-by-side, and it is desired to memorialize on one (1) tablet the two persons, then the foregoing would apply. This larger tablet would be placed and installed instead of two (2) separate 20" x 12" tablets, provided that it is set to embrace evenly the two grave plots concerned.

(ii) Sections G1 (Lawn Crypts) & G4 On Full Size Adult Graves in Section

(A) Designated Upright Sections

Maximum size upright
30" x 6" x 20" (mandatory 6" Base, minimum 2"
margin)
All uprights minimum thickness 6"

(B) Designated Flat Sections

20" x 12"

(iii) Section G3 (PGIG Cremation Garden) & G5 & G6

(A) Designated Companion Plots for G3

20" x 12" bronze marker mounted on pinkish
granite 24" x 16" polished top side.

(B) Designated Family Plots

24 x 16" Bronze Maker c/w Flower Vase
Mounted on Pinkish Granite pillow 28" wide x
28" long polished top side rock pitch
4 sides hickey with a 10" Top Nose with 6" core
hole for vase and drilled for 24" x 16"
Matthews bronze plaque template.

(C) Family Bronze Scrolls

For memorializing successive Members on
Family Marker 6.5" x 2.13" Scroll includes
Name on First line and Dates on Second Line to
be drilled/tapped for mounting on Plaque.

(D) Companion Plots Section G5 & G6

20" x 12" marker.

(E) Family Cremation Plot Sections G5 & G6

24" X 16" bronze marker preferably mounted
on 28" x 20" granite.

(iv) Section G7

BL9738 amended clause (A):

(A) Designated Upright Sections Maximum size upright 30" x 6" x 20"
(mandatory 6" Base with, minimum 2' front
and rear margin, maximum length 35 inches).
All uprights minimum thickness 6".

(B) Designated Flat Sections

20" x 12"

(C) Garden Estates

One (1) upright memorial including base not to exceed 60 x 14 x 44 (minimum 2' margin) placed upon the provided foundation. Individual cremation memorials will be 20" x 12" made of bronze and mounted on granite base with a 2 inch margin.

All approved ornamentation such as large flower vases must be made of granite or other materials that are approved by the Cemetery Manager

- (v) On Child Plots 20" x 12"
- (vi) On Infant Plots 12" x 8"
- (vii) On Cremation Plots 14" x 10"

*The placement of additional memorials for Cremation required on the surface of full size adult graves should be 20" X 12" and placed according to Section 10.8 (c).

(viii) Bennett Memorial Columbarium & Promontory Green Interment Garden

Niche Nameplate.

The minimum requirements for the niche nameplate shall be:

- (A) a single bronze cast niche wreath 10" x 7", to be mounted on the two pre-drilled holes that are seven (7) inches apart, centred on the niche door,
 - (B) the lettering to consist of surname and given name and/or initials for an individual and/or companion; lettering shall be on three (3) separate lines as follows:
 - (1) First line - to include surname in lettering $\frac{3}{4}$ inch in height;
 - (2) Second line - to include the given name and/or initials in lettering $\frac{1}{2}$ inch in height; and
 - (3) Third line - to include year of birth and year of death, in lettering $\frac{1}{4}$ inch in height, with lettering sizes to be adjusted accordingly in the event of a long surname.
 - (C) lettering to be in Renic font, and name plate to be hand chased and polished,
- BL9738 added (D) and (E) to the end of sub-section (viii) the following:
- (D) Where a niche plate is engraved, inscriptions shall be carved into the surface to a depth of 0.3 cm ($\frac{1}{8}$ ") in Roman Classic letters and figures.
 - (E) Inscriptions for companion niches shall be composed of six (6) lines centred.
 - (1) First line - to include family surname(s) in lettering 1 & $\frac{1}{4}$ inch in height;
 - (2) Second line - to include the given names(s) of the first inurnment in lettering $\frac{7}{8}$ inch in height;
 - (3) Third line - to include year of birth and the year of death in lettering $\frac{7}{8}$ inch in height;
 - (4) Fourth line - to include the given name(s) of the second inurnment in lettering $\frac{7}{8}$ inch in height;
 - (5) Fifth line - to include year of birth and the year of death in lettering $\frac{7}{8}$ inch in height;
 - (6) Sixth line - to include a sentiment or phrase, in lettering $\frac{1}{2}$ inch in height, that is in keeping with the dignity of the Cemetery, adjacent niches and community standards; and
 - (7) All names, initials, title, rank, sentiment, phrases, etc are carved on the particular line as space permits.

- (ix) Mausoleum Crypt Nameplate. The minimum requirements for the crypt nameplate shall be:
- (A) Matthews Abby Companion a single bronze cast crypt plate 30 inches by 7 1/8 inches, or 30 inches by 10 5/8 inches centered on the crypt door.
 - (B) Matthews Abby Individual a single bronze cast crypt plate 24 inches by 7 3/16 inches, or 24 inches by 11 inch centered on the crypt door.
 - (C) the lettering to consist of surname and given name and/or initials for an individual and/or companion; lettering shall be on three (3) separate lines as follows:
 - First line - to include surname in lettering 1 1/4 inch in height;
 - Second line - to include the given name and/or initials in lettering 3/4 inch in height; and
 - Third line - to include year of birth and year of death, in lettering 1/2 inch in height, with lettering sizes to be adjusted accordingly in the event of a long surname,
 - (D) lettering to be in Renic font, and name plate to be hand chased and polished.

SCHEDULE "F"

SPECIFICATIONS FOR MONUMENTS IN SECTION E-4

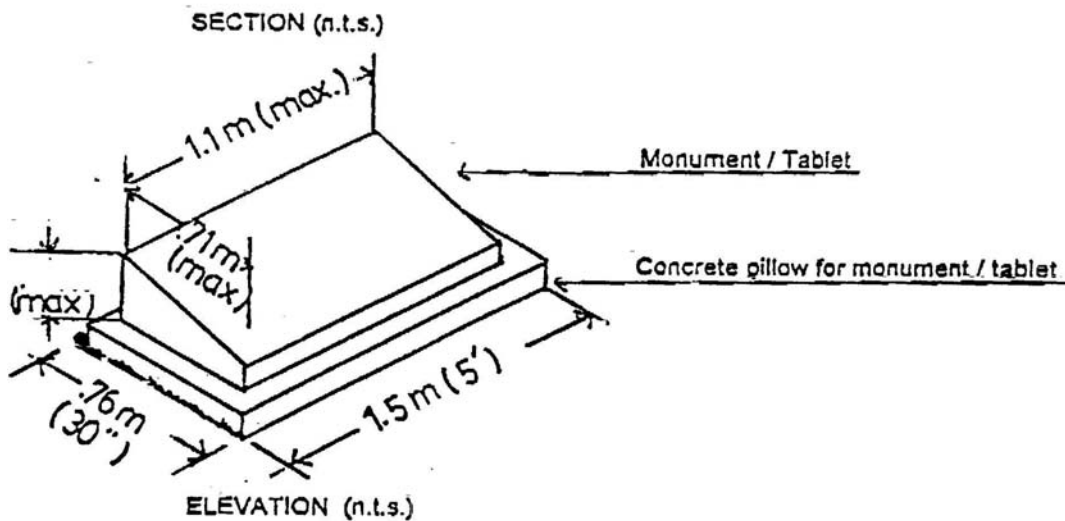
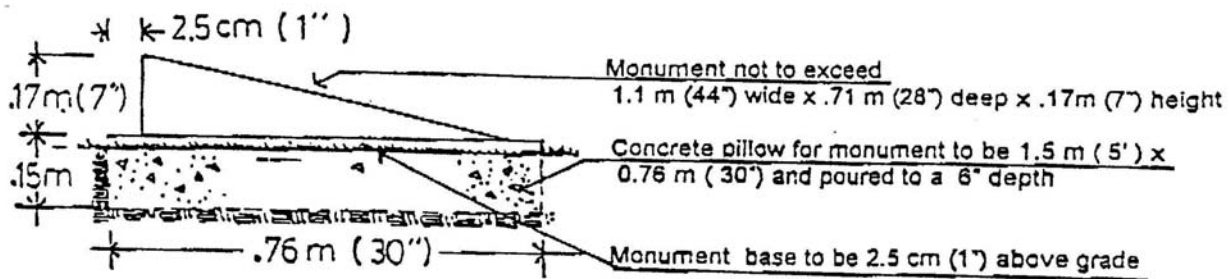

Specifications for regular graves in Section E4

Any memorial marker, tablet, or monument shall be constructed of stone, concrete or metal and shall not exceed the following maximum size:

1.1 m. (44") wide x 0.71 m. (.28") deep x 0.17 m. (7") in height

No grave or grave space is to be defined by a fence, coping, curbing or hedge or by any other marking save and except by a memorial.

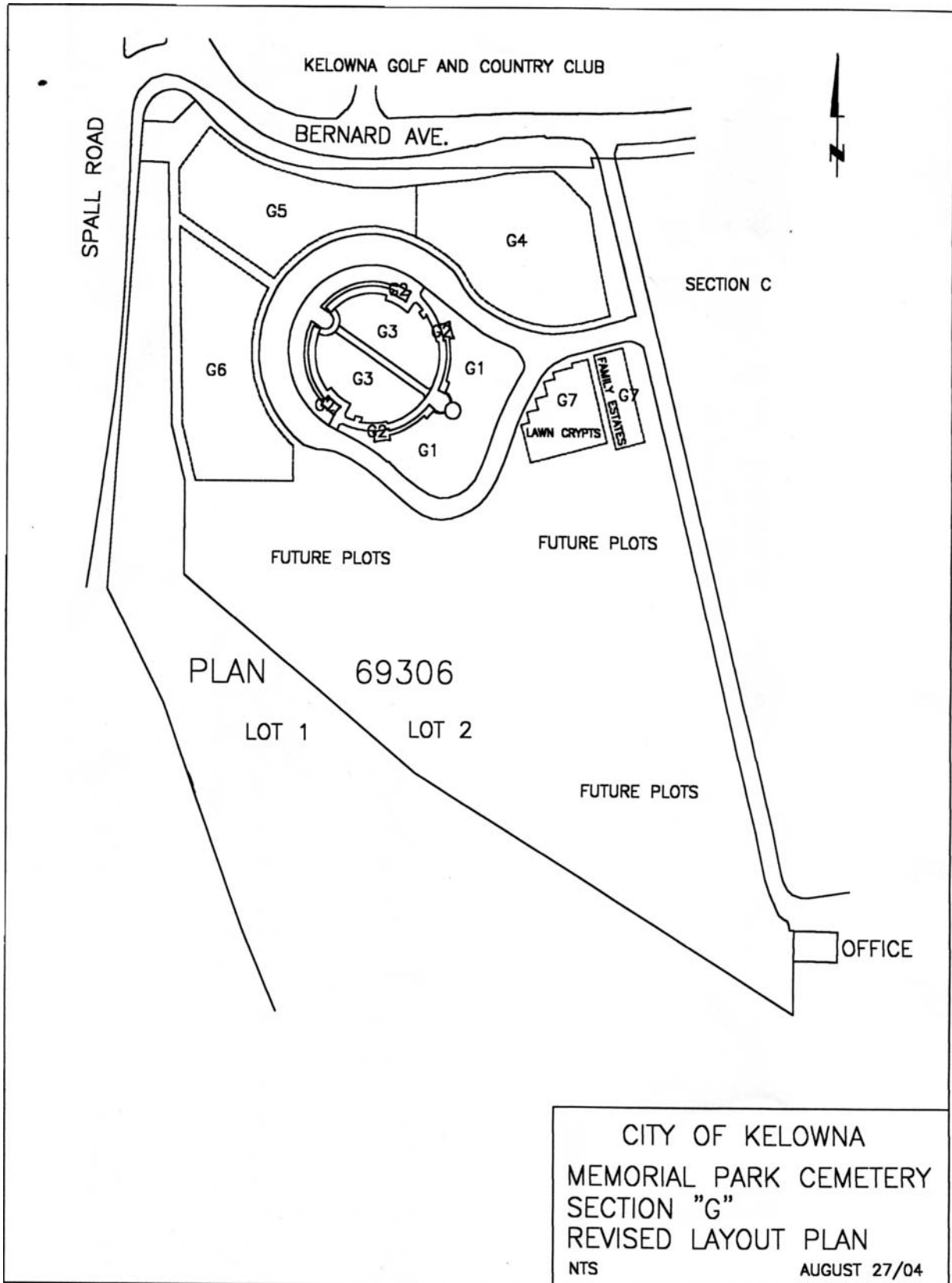

CITY OF KELOWNA
MEMORIAL PARK CEMETERY
SECTION "G"
REVISED LAYOUT PLAN
NTS
AUGUST 27/04